

Ball Screw Support Bearings

TAB Series

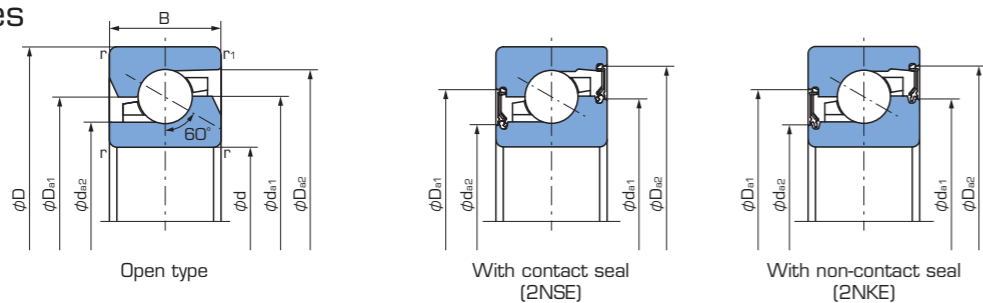

Dynamic equivalent axial load $P_a = X Fr + Y Fa$

No. of bearings in set	2		3			4				
	1 row	2 rows	1 row	2 rows	3 rows	1 row	2 rows	3 rows	4 rows	
$Fa/Fr \leq 2.17$	X	1.90	-	1.43	2.33	-	1.17	2.33	2.53	-
	Y	0.54	-	0.77	0.35	-	0.89	0.35	0.26	-
$Fa/Fr > 2.17$	X	0.92	0.92	0.92	0.92	0.92	0.92	0.92	0.92	0.92
	Y	1	1	1	1	1	1	1	1	1

Bearing No.	Boundary dimensions (mm)					Basic dynamic load rating ⁽²⁾ Ca (kN)		Axial limiting load ⁽³⁾ (kN)	Limiting speed ⁽⁴⁾ (min ⁻¹)		Reference dimensions (mm)				Mass (kg) (Reference)	Bearing No.
	d	D	B	r _{min}	r _{1 min}	Standard	Multi-tough		Grease lubrication	Oil lubrication	da ₁	da ₂	Da ₁	Da ₂		
15TAB04	15	47	15	1 ⁽¹⁾	0.6	25.9	32.5	32.0	6,300	8,000	33.7	26.8	33.5	41.0	0.14	15TAB04
15TAB04-2NKE	15	47	15	1 ⁽¹⁾	0.6	25.9	32.5	32.0	6,300	-	32.9	26.0	35.5	41.8	0.14	15TAB04-2NKE
15TAB04-2NSE	15	47	15	1 ⁽¹⁾	0.6	25.9	32.5	32.0	6,300	-	32.9	26.0	35.5	41.8	0.14	15TAB04-2NSE
17TAB04	17	47	15	1	0.6	25.9	32.5	32.0	6,300	8,000	33.7	26.8	33.5	41.0	0.13	17TAB04
17TAB04-2NKE	17	47	15	1	0.6	25.9	32.5	32.0	6,300	-	32.9	26.0	35.5	41.8	0.13	17TAB04-2NKE
17TAB04-2NSE	17	47	15	1	0.6	25.9	32.5	32.0	6,300	-	32.9	26.0	35.5	41.8	0.13	17TAB04-2NSE
20TAB04	20	47	15	1	0.6	25.9	32.5	32.0	6,300	8,000	33.7	26.8	33.5	41.0	0.12	20TAB04
20TAB04-2NKE	20	47	15	1	0.6	25.9	32.5	32.0	6,300	-	32.9	26.0	35.5	41.8	0.12	20TAB04-2NKE
20TAB04-2NSE	20	47	15	1	0.6	25.9	32.5	32.0	6,300	-	32.9	26.0	35.5	41.8	0.12	20TAB04-2NSE
25TAB06	25	62	15	1	0.6	29.9	38.0	46.4	4,650	6,000	46.2	39.7	46.0	53.4	0.24	25TAB06
25TAB06-2NKE	25	62	15	1	0.6	29.9	38.0	46.4	4,650	-	45.0	38.5	47.8	55.0	0.24	25TAB06-2NKE
25TAB06-2NSE	25	62	15	1	0.6	29.9	38.0	46.4	4,650	-	45.0	38.5	47.8	55.0	0.24	25TAB06-2NSE
30TAB06	30	62	15	1	0.6	29.9	38.0	46.4	4,650	6,000	46.2	39.7	46.0	53.4	0.21	30TAB06
30TAB06-2NKE	30	62	15	1	0.6	29.9	38.0	46.4	4,650	-	45.0	38.5	47.8	55.0	0.21	30TAB06-2NKE
30TAB06-2NSE	30	62	15	1	0.6	29.9	38.0	46.4	4,650	-	45.0	38.5	47.8	55.0	0.21	30TAB06-2NSE
35TAB07	35	72	15	1	0.6	32.5	41.0	54.3	3,750	5,000	56.2	49.7	56.0	63.4	0.29	35TAB07
35TAB07-2NKE	35	72	15	1	0.6	32.5	41.0	54.3	3,750	-	55.0	48.5	57.8	64.9	0.29	35TAB07-2NKE
35TAB07-2NSE	35	72	15	1	0.6	32.5	41.0	54.3	3,750	-	55.0	48.5	57.8	64.9	0.29	35TAB07-2NSE
40TAB07	40	72	15	1	0.6	32.5	41.0	54.3	3,750	5,000	56.2	49.7	56.0	63.4	0.26	40TAB07
40TAB07-2NKE	40	72	15	1	0.6	32.5	41.0	54.3	3,750	-	55.0	48.5	57.8	64.9	0.26	40TAB07-2NKE
40TAB07-2NSE	40	72	15	1	0.6	32.5	41.0	54.3	3,750	-	55.0	48.5	57.8	64.9	0.26	40TAB07-2NSE
40TAB09	40	90	20	1	0.6	65.0	82.0	101	3,150	4,000	67.2	57.2	67.0	78.4	0.62	40TAB09
40TAB09-2NKE	40	90	20	1	0.6	65.0	82.0	101	3,150	-	65.7	55.7	69.8	80.8	0.62	40TAB09-2NKE
40TAB09-2NSE	40	90	20	1	0.6	65.0	82.0	101	3,150	-	65.7	55.7	69.8	80.8	0.62	40TAB09-2NSE
45TAB07	45	75	15	1	0.6	33.5	42.5	59.5	3,400	4,500	61.7	55.2	61.5	68.9	0.25	45TAB07
45TAB07-2NKE	45	75	15	1	0.6	33.5	42.5	59.5	3,400	-	60.5	54.0	63.3	70.3	0.25	45TAB07-2NKE
45TAB07-2NSE	45	75	15	1	0.6	33.5	42.5	59.5	3,400	-	60.5	54.0	63.3	70.3	0.25	45TAB07-2NSE
45TAB10	45	100	20	1	0.6	68.0	86.0	113	2,850	3,500	74.2	64.2	74.0	85.4	0.79	45TAB10
45TAB10-2NKE	45	100	20	1	0.6	68.0	86.0	113	2,850	-	72.7	62.7	76.8	87.8	0.79	45TAB10-2NKE
45TAB10-2NSE	45	100	20	1	0.6	68.0	86.0	113	2,850	-	72.7	62.7	76.8	87.8	0.79	45TAB10-2NSE
50TAB10	50	100	20	1	0.6	69.5	88.0	119	2,700	3,500	78.2	68.2	78.0	89.4	0.72	50TAB10
50TAB10-2NKE	50	100	20	1	0.6	69.5	88.0	119	2,700	-	76.7	66.7	80.8	91.8	0.72	50TAB10-2NKE
50TAB10-2NSE	50	100	20	1	0.6	69.5	88.0	119	2,700	-	76.7	66.7	80.8	91.8	0.72	50TAB10-2NSE
55TAB10	55	100	20	1	0.6	69.5	88.0	119	2,700	3,500	78.2	68.2	78.0	89.4	0.95	55TAB10
55TAB10-2NKE	55	100	20	1	0.6	69.5	88.0	119	2,700	-	76.7	66.7	80.8	91.8	0.95	55TAB10-2NKE
55TAB10-2NSE	55	100	20	1	0.6	69.5	88.0	119	2,700	-	76.7	66.7	80.8	91.8	0.95	55TAB10-2NSE
55TAB12	55	120	20	1	0.6	73.0	92.5	137	2,300	3,000	92.2	82.2	92.0	103.4	1.15	55TAB12
55TAB12-2NKE	55	120	20	1	0.6	73.0	92.5	137	2,300	-	90.7	80.7	94.8	105.8	1.15	55TAB12-2NKE
55TAB12-2NSE	55	120	20	1	0.6	73.0	92.5	137	2,300	-	90.7	80.7	94.8	105.8	1.15	55TAB12-2NSE
60TAB12	60	120	20	1	0.6	73.0	92.5	137	2,300	3,000	92.2	82.2	92.0	103.4	1.08	60TAB12
60TAB12-2NKE	60	120	20	1	0.6	73.0	92.5	137	2,300	-	90.7	80.7	94.8	105.8	1.08	60TAB12-2NKE
60TAB12-2NSE	60	120	20	1	0.6	73.0	92.5	137	2,300	-	90.7	80.7	94.8	105.8	1.08	60TAB12-2NSE

(Note 1) Minimum r for inner ring is 0.6.

(Note 2) When the axial load is on a 2-row or 3-row arrangement, the values in the table should be multiplied by 1.62 and 2.16 respectively.

(Note 3) When the axial load is on a 2-row or 3-row arrangement, the values in the table should be multiplied by 2 and 3 respectively.

(Note 4) Limiting speed for M preload.